

Technical Documentation Wind Turbine Generator Systems 3.8-130 - 50/60 Hz



Technical Description and Data



imagination at work

www.gepower.com

Visit us at
<https://renewable.gepower.com>

Copyright and patent rights

All documents are copyrighted within the meaning of the Copyright Act. We reserve all rights for the exercise of commercial patent rights.

© 2016 General Electric Company. All rights reserved.

This document is public. GE and  are trademarks and service marks of General Electric Company.

Other company or product names mentioned in this document may be trademarks or registered trademarks of their respective companies.



imagination at work

Table of Contents

- 1 Introduction 5
- 2 Technical Description of the Wind Turbine and Major Components 5
 - 2.1 Rotor 5
 - 2.2 Blades 6
 - 2.3 Blade Pitch Control System 7
 - 2.4 Hub 7
 - 2.5 Gearbox 7
 - 2.6 Bearings 7
 - 2.7 Brake System 7
 - 2.8 Generator 7
 - 2.9 Gearbox/Generator Coupling 7
 - 2.10 Yaw System 8
 - 2.11 Tower 8
 - 2.12 Nacelle 8
 - 2.13 Wind Sensor and Lightning Rod 8
 - 2.14 Lightning Protection (according to IEC 61400-24 Level I) 8
 - 2.15 Wind Turbine Control System 9
 - 2.16 Power Converter 9
 - 2.17 Medium Voltage Transformer and Switch Gear 9
- 3 Technical Data for the 3.8-130 10
 - 3.1 Operational Limits 12

1 Introduction

This document summarizes the technical description and specifications of the 3.8-130 wind turbines.

2 Technical Description of the Wind Turbine and Major Components

The 3.8-130 is a three-bladed, upwind, horizontal-axis wind turbine with a rotor diameter of 130 meters. The turbine rotor and nacelle are mounted on top of:

- a tubular steel tower with a hub height of 85 m
- a tubular steel tower with a hub height of 110 m
- a concrete/steel hybrid tower with a hub height of 134 m
- a concrete/steel hybrid tower with a hub height of 164.5 m

The dimensions of the 3.8-130 with 85 m, 110 m 134 m and 164.5 m hub height are shown in attached drawings.

The 3MW Platform employs active yaw control (designed to steer the wind turbine with respect to the wind direction), active blade pitch control (to regulate turbine rotor speed) and a variable speed generator with a power electronic converter system.

The 3MW Platform features a modular drive train design where the major drive train components including main shaft bearing, gearbox, generator and yaw drives are attached to a bedplate.

2.1 Rotor

Rotor speed is regulated by a combination of blade pitch angle adjustment and generator/converter torque control. The rotor spins in a clockwise direction under normal operating conditions when viewed from an upwind location.

Full blade pitch angle range is approximately 90 degrees, with the zero degree position being with the blade flat to the prevailing wind. Pitching the blades to a full feather pitch angle of approximately 90 degrees accomplishes aerodynamic braking of the rotor, thus reduces the rotor speed.

2.2 Blades

There are three rotor blades used on the 3.8-130 wind turbine. The airfoils transition along the blade span and with the thicker airfoils being located inboard towards the blade root (hub) and gradually tapering to thinner cross sections out towards the blade tip. Values below are typically needed to perform shadow casting calculations.

	Rotor Diameter
	130 m
Longest chord	4.00 m
Chord at 0.9 x rotor radius	1.10 m

In order to optimize noise emissions, the rotor blades are equipped with Low-Noise-Trailing-Edges (LNTes) at the pressure side of the blade's rear edge. LNTes are thin jagged plastic strips. The rotor blades of the 3.8-130 are equipped with these strips at the factory.



Fig. 1: LNTes at the WTG

2.3 Blade Pitch Control System

The rotor utilizes a pitch system to provide adjustment of the blade pitch angle during operation.

The active pitch controller enables the wind turbine rotor to regulate speed, when above rated wind speed, by allowing the blade to “spill” excess aerodynamic lift. Energy from wind gusts below rated wind speed is captured by allowing the rotor to speed up.

Independent back up is provided to drive each blade in order to feather the blades and shut down the wind turbine in the event of a grid line outage or other fault. By having all three blades outfitted with independent pitch systems, redundancy of individual blade aerodynamic braking capability is provided.

2.4 Hub

The hub is used to connect the three rotor blades to the turbine main shaft. The hub also houses the blade pitch system and is mounted directly to the main shaft. To carry out maintenance work, the hub can be entered through one of three hatches at the area close to the nacelle roof.

2.5 Gearbox

The gearbox in the wind turbine is designed to transmit torsional power between the low-rpm turbine rotor and high-rpm electric generator. The gearbox is a multi-stage planetary/helical design. The gearbox is mounted to the wind turbine bedplate. The gearbox mounting is designed to reduce vibration and noise transfer to the bedplate. The gearbox is lubricated by a forced, cooled lubrication system and a filter assist to maintain oil cleanliness.

2.6 Bearings

The blade pitch bearing is designed to allow the blade to pitch about a span-wise pitch axis. The inner race of the blade pitch bearing is outfitted with a blade drive gear that enables the blade to be driven in pitch. The main shaft bearing is a two-bearing system, designed to provide bearing and alignment of the internal gearing shafts and accommodate radial and axial loads.

2.7 Brake System

The blade pitch system acts as the main braking system for the wind turbine. Braking under normal operating conditions is accomplished by feathering the blades out of the wind. Only two feathered rotor blades are required to decelerate the rotor safely into idling mode, and each rotor blade has its own backup to drive the blade in the event of a grid line loss.

2.8 Generator

The generator is a doubly fed induction generator. It is mounted to the bedplate with a mounting so designed as to reduce vibration and noise transfer to the bedplate.

2.9 Gearbox/Generator Coupling

To protect the drive train from excessive torque loads, a special coupling including a torque-limiting device is provided between the generator and gearbox output shaft.

2.10 Yaw System

A bearing positioned between the nacelle and tower facilitates yaw motion. Yaw drives mesh with the gear of the yaw bearing and steer the wind turbine to track the wind in yaw. The yaw drive system contains an automatic yaw brake. This brake engages when the yaw drive is not operating and prevents the yaw drives from being loaded due to turbulent wind conditions.

The controller activates the yaw drives to align the nacelle to the wind direction based on the wind vane sensor mounted on the top of the nacelle.

The wind turbine records nacelle yaw position following excessive rotation in one direction, the controller automatically brings the rotor to a complete stop, untwists the internal cables, and restarts the wind turbine.

2.11 Tower

The wind turbine is mounted on top of a tubular steel tower (85 m, 110 m hub height) or a hybrid tower (134 m, 164.5 m hub height). Access to the turbine is through a door at the base of the tower. Internal service platforms and interior lighting is included. A ladder provides access to the nacelle and also supports a fall arrest safety system.

Optional climb assist or service lifts are available upon request.

2.12 Nacelle

The nacelle houses the main components of the wind turbine generator. Access from the tower into the nacelle is through the bottom of the nacelle. The nacelle is ventilated, and illuminated by electric lights. A hatch provides access to the blades and hub.

2.13 Wind Sensor and Lightning Rod

An ultrasonic wind sensor and lightning rod are mounted on top of the nacelle housing. Access is accomplished through the hatch in the nacelle.

2.14 Lightning Protection (according to IEC 61400-24 Level I)

The rotor blades are equipped with lightning receptors mounted in the blade. The turbine is grounded and shielded to protect against lightning; however, lightning is an unpredictable force of nature and it is possible that a lightning strike could damage various components notwithstanding the lightning protection employed in the wind turbine.

2.15 Wind Turbine Control System

The wind turbine can be controlled locally. Control signals can also be sent from a remote computer via a Supervisory Control and Data Acquisition System (SCADA), with local lockout capability provided at the turbine controller.

Service switches at the tower top prevent service personnel at the bottom of the tower from operating certain systems of the turbine while service personnel are in the nacelle. To override any wind turbine operation, emergency-stop buttons located in the tower base and in the nacelle can be activated to stop the turbine in the event of an emergency.

2.16 Power Converter

The wind turbine uses a power converter system that consists of a converter on the rotor side, a DC intermediate circuit, and a power inverter on the grid side.

The converter system consists of a power module and the associated electrical equipment.

2.17 Medium Voltage Transformer and Switch Gear

To connect each turbine to the collector system, a medium voltage transformer and medium-voltage switchgear are required. These devices may be either installed in the tower (GE scope) or external to the tower as part of a Pad Mount Transformer (customer scope).

3 Technical Data for the 3.8-130

Turbine	3.8-130
Rated output [MW]	3.83
Rotor diameter [m]	130
Number of blades	3
Swept area [m ²]	13273
Rotational direction (viewed from an upwind location)	Clockwise
Maximum speed of the blade tips [m/s]	82.4
Orientation	Upwind
Speed regulation	Pitch control
Aerodynamic brake	Full feathering
Color of outer components	RAL 7035 (light grey)
Reflection degree/Gloss degree Steel tower	30 - 60 units measured at 60 ° per ISO 2813
Reflection degree/Gloss degree Rotor blades, Nacelle, Hub	60 - 80 Gloss Units measured at 60 ° as per ISO 2813

Table 1: Technical data 3.8-130 wind turbine

Atmospheric corrosion protection (corrosion categories as defined by ISO 12944-2:1998)					
		Standard		Enhanced (Option)	
		Internal	External	Internal	External
Americas	Tower shell	C-2	C-3	C-4	C-5M
	All other components	C-2	C-3	C-2	C-3
Europe	Tower shell	C-4	C-5M		
	All other components	C-2	C-3		

Table 2: Atmospheric corrosion protection

3.1 Operational Limits

Turbine	3.8-130
Hub height	85 m tubular steel tower*/** 110 m tubular steel tower* 134 m hybrid tower** 164.5 m hybrid tower**
Wind turbine design standard	* IEC 61400-1, Ed. 3 ** DIBt 2012
Height above sea level	Maximum 1000 m with the maximum standard operational temperature of +40 °C. Above 1000 m, the maximum operational temperature is reduced per DIN IEC 60034 1 (e.g., maximum operational temperature reduced to +30 °C at 2000 m). For installations above 1000 m isolation distances of medium voltage terminals must also be re-evaluated.
Standard Weather Option (STW)	Full power operation from -15°C to +35°C, resp. 5°F to +95°F; de-rate to reach +40°C Survival temperature of -20°C to +50°C, resp. -4°F to +122°F without the grid. Survival means: turbine not in operation including the heat transfer system due to lack of energy supply by the grid.
Cold Weather Option (CW)	Full power operation from -30°C to +35°C resp. -22°F to +95°F. Survive extreme temperature of -40°C to +50°C, resp. -40°F to +122°F without the grid. Survive means: turbine not in operation including the heat transfer system due to lack of energy supply by the grid.
Wind conditions according to IEC 61400 1 (ed. 3) for the standard temperature range	8.5 m/s
Maximum extreme gust (10 min) according to IEC 61400 1 (ed. 3) for the standard temperature range	42.5 m/s
Wind class	IEC IIb

Table 3: Operational limits

NOTES:
THIS DRAWING SHOWS A STANDARD CONFIGURATION TO GERMAN REGULATIONS ONLY.
OTHER COUNTRY AND SITE SPECIFIC REGULATION MAY VARY.

DIMENSIONS AND DESCRIPTION IN () ARE OPTIONAL.
DIMENSIONS AND DESCRIPTION IN [] ARE ALTERNATIVE
MARKINGS, WHICH CAN BE USED INSTEAD.

1. ECCENTRICITY EB: DISTANCE BETWEEN TOWER CENTER AND BLADE TIP IN OPERATION.
2. DISTANCE AD: DISTANCE BETWEEN TOWER CENTER AND BLADE TIP IN OPERATION.
3. DAY-LIGHT IDENTIFICATION 3x6m ON EACH BLADE
RED LIGHT: RED [] RAL 3020, 7035, 3020
ALTERNATIVE: [] ORANGE WHITE ORANGE: RAL 2009, 5016, 2009
4. NIGHT IDENTIFICATION:
*NO AVIATION LIGHTS.
5. DAY-LIGHT IDENTIFICATION BOTH SIDES AND BACK OF NACELLE:
2m RED [] RAL 3020
ALTERNATIVE: [] 2m ORANGE: RAL 2009
6. DAY-LIGHT IDENTIFICATION AT TOWER:
3m RED [] RAL 3020
ALTERNATIVE: [] 3m ORANGE: RAL 2009
7. NIGHT IDENTIFICATION:
4 AVIATION LIGHTS.
8. FOUNDATION SHOWN IS FOR INFORMATION ONLY.
9. ECCENTRICITY ES: DISTANCE BETWEEN TOWER CENTER AND BLADE TIP IN IDLE.
10. DISTANCE AS: DISTANCE BETWEEN TOWER CENTER AND BLADE TIP IN IDLE.
11. DISTANCE FROM TOWER CENTER TO BLADE TIP IN IDLE AREA: 13,509,03m
12. DISTANCE FROM TOWER CENTER TO BLADE TIP IN OPERATION AREA: 13,587,45m

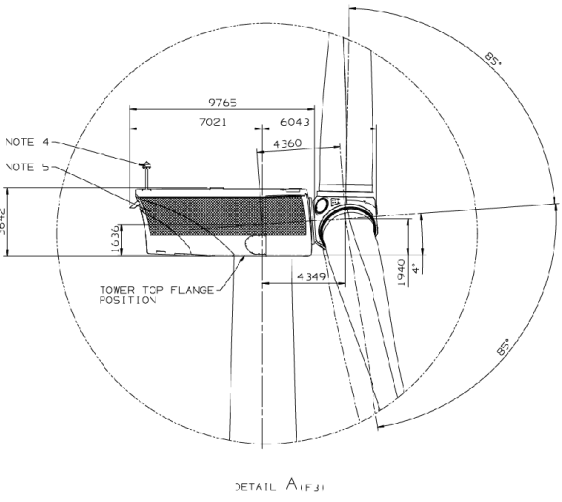
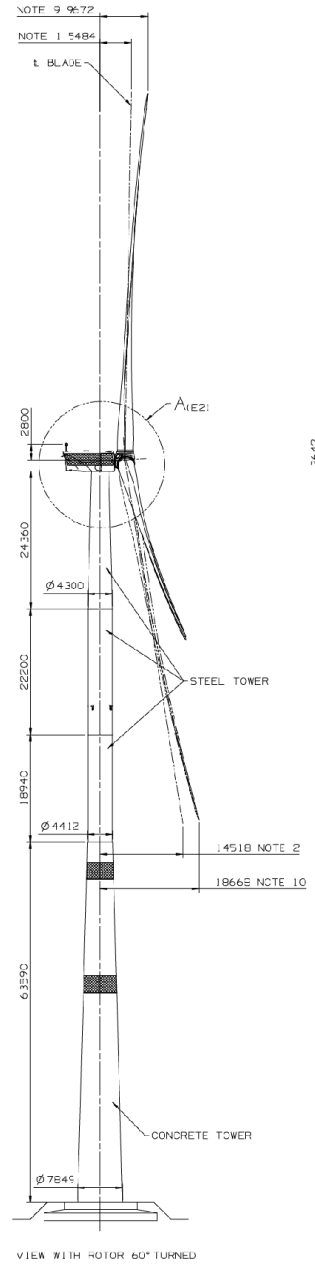
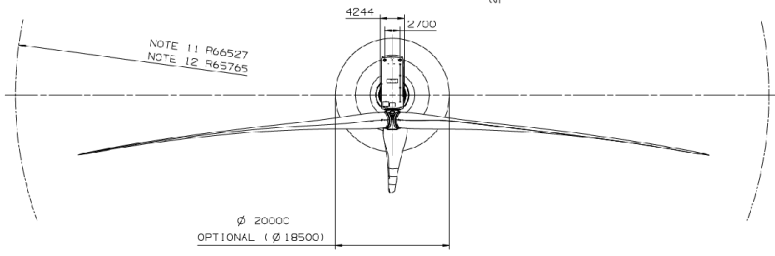
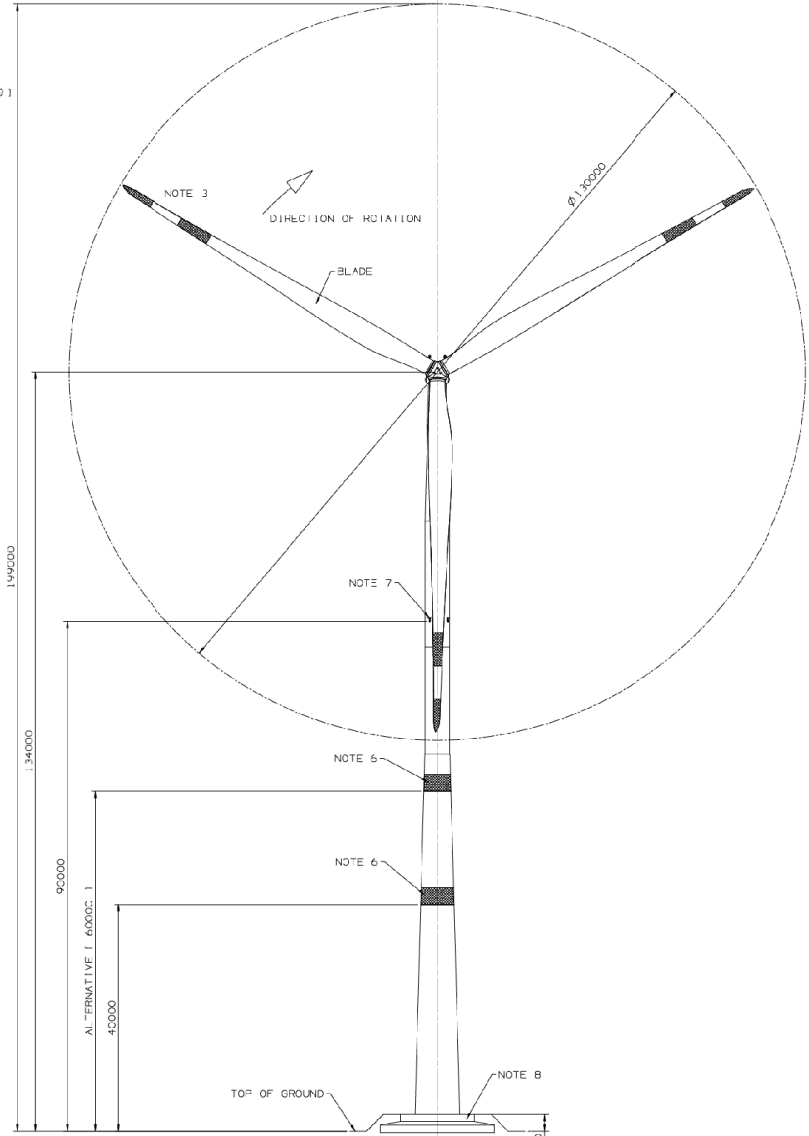

REV. NO.		444W0126		REV. BY		DATE		APPROVED	
REV. NO.	DESCRIPTION	DATE (YYYY MM DD)	APPROVED	DATE (YYYY MM DD)	APPROVED	DATE (YYYY MM DD)	APPROVED	DATE (YYYY MM DD)	APPROVED
B	(1) ADDED NOTE 11 AND 12 PER ECR3039202	2016-05-10	DRAWN 105015424						

REVISE ON CAD ONLY
NK PART: 444W0126

© COPYRIGHT 2015-2016 General Electric Company (USA).
All rights reserved. The information herein is proprietary and technical. It is the exclusive content of GE and is not to be disclosed, copied, or used in any form without the prior written consent of GE. This information is provided for informational purposes only and is not intended to be used for any other purpose. GE reserves the right to change this information without notice.

UNLESS OTHERWISE SPECIFIED		DIMENSIONS ARE IN MILLIMETERS		TOLERANCE CLASS:		TYPE: OUTLINE	
NA	NA	NA	NA	NA	NA	NA	NA
DRAWN DATE: 17/11/14		DRAWN BY: []		CHECKED BY: []		DATE: 2015-05-11	
FIRST ANGLE PROJECTION		CHECK DATE: 17/11/14		DRAWN DATE: 17/11/14		DRAWN BY: []	
ADDITIONAL APPROVALS FOR REVISIONS		FOR REVISIONS		FOR REVISIONS		FOR REVISIONS	
DWG SOURCE: []		DWG DATE: []		DWG SCALE: []		DWG NO: []	
DWG NO: []		SCALE: []		CASE CODE: []		DWG NO: []	
DWG NO: []		SCALE: []		CASE CODE: []		DWG NO: []	

GE CLASS 11 (INTERNAL NON-CRITICAL)
GE RENEWABLE ENERGY
TURBINE 134MH, 130W ROTOR
HYBRID TOWER

SIZE: [] CASE CODE: [] DWG NO: []
AO NONE 444W0126
SCALE: [] SHEET: [] OF []

THIS DRAWING IS PREPARED IN ACCORDANCE WITH ISO 1101:2004